



EN ■ Pedestal Fan

READ CAREFULLY AND STORE FOR FUTURE USE.

- This appliance may be used by children 8 years of age and older and by persons with physical or mental impairments or by inexperienced persons, if they are properly supervised or have been informed about how to use the product in a safe manner and understand the potential dangers. Cleaning and user maintenance must not be performed by children unless they are older than 8 years of age and under supervision. Keep this appliance and the power cord out of reach of children that are younger than 8 years of age. Children must not play with the appliance.
- Before connecting the appliance to a power socket, check that the rated voltage on its rating label matches the electrical voltage in the power socket.
- Connect the appliance only to a properly grounded socket.
- The appliance is designed for use at home, in offices and similar types of areas. Do not use it in very dusty or humid rooms such as laundries or bathrooms, in areas where chemical or explosive substances are stored, in industrial surroundings or outdoors.
- Do not place the appliance in the vicinity of an open flame or appliances that are sources of heat.
- Do not place the appliance on unstable surfaces such as carpets with very long and thick fibres. Place the appliance on a clean, even, dry and smooth surface.
- Before turning it on, check that the appliance is correctly assembled according to the instructions in this user's manual. Do not start the appliance without the protective grills properly installed. Only use original parts to assemble the appliance.
- Do not cover the appliance with any items while it is running.
- Avoid coming into contact with the rotating parts of the appliance. Never insert your fingers or other items through the protective grill when the appliance is plugged into a power socket. This applies particularly when the appliance is in operation.
- Never submerge the appliance or its power cord in water or any other liquid and do not wash it under running water.
- Make sure the power cord is placed in such a way that nobody can trip over it and or that it is not touching a hot surface.
- Always turn off the appliance and disconnect it from the power socket when leaving it without supervision, when not using it and before assembly, disassembly or cleaning it.

- Disconnect the appliance from the power socket by pulling on the plug, never pulling on the power cord. Otherwise, this could damage the power cord or the socket.
- If the power cord is damaged, it must be replaced by an authorised service centre or by another similarly qualified person, this will prevent the creation of a dangerous situation. It is forbidden to use the appliance if it has a damaged power cord.
- Do not use the appliance if it is not working correctly, if it has been damaged or has been submerged in water. To avoid a hazardous situation arising, do not repair the device yourself or modify it in any way. Have all repairs performed at an authorised service centre. By tampering with the appliance, you risk voiding your legal rights arising from unsatisfactory performance or quality warranty.

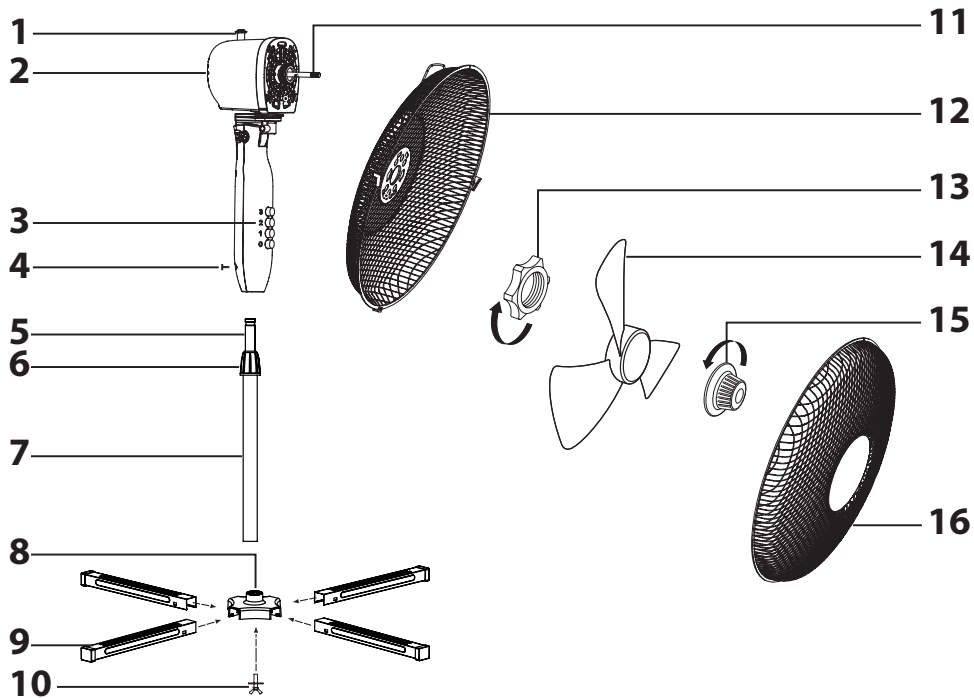
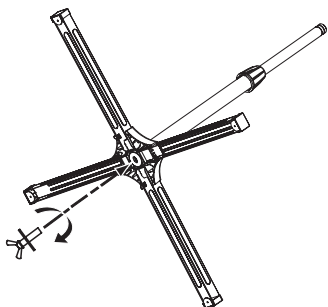
A**B**

- Prior to using this appliance, please read the user's manual thoroughly, even in cases, when one has already familiarised themselves with previous use of similar types of appliances. Only use the appliance in the manner described in this user's manual. Keep this user's manual in a safe place where it can be easily retrieved for future use.
- We recommend saving the original cardboard box, packaging material, purchase receipt and responsibility statement of the vendor or warranty card for at least the duration of the legal liability for unsatisfactory performance or quality. In the event of transportation, we recommend that you pack the appliance in the original box from the manufacturer.

DESCRIPTION OF THE APPLIANCE

- A1** Horizontal oscillation toggle switch
A2 Motor unit with adjustable vertical tilt angle
A3 Panel with control buttons
 0 – off, 1 – low speed, 2 – medium speed, 3 – high speed
A4 Screw for fastening the control panel to the extensible pole
A5 Inner extensible pole
A6 Inner extension lock
A7 Outer pole
A8 Cross base central connecting piece
A9 Cross base feet
A10 Butterfly screw with washer
 Serves to fasten the outer pole to the base.
A11 Motor unit shaft
A12 Rear protective grill with fastening clamps and a carry handle
A13 Rear protective grill fastening nut
A14 Fan blades with a diameter of 40 cm
A15 Fan blade fastening nut
A16 Front protective grill



Note:

The accessories include a screw and a nut for joining the protective grills.

BEFORE FIRST USE

- Take the appliance and its accessories out of the packaging materials. Before disposing of the packaging materials, make sure that no part of the appliance is missing.

ASSEMBLING AND DISASSEMBLING THE APPLIANCE

- Before assembling or disassembling the appliance, make sure that it is turned off and disconnected from the power socket.
- Secure the feet **A9** in the cross base central connecting piece **A8**. Fit the outer pole **A7** from above into the cross base connecting piece **A8** and fasten from underneath using the butterfly screw **A10** (see fig. B).
- Use one hand to firmly hold the outer pole **A7** and the other hand to release the inner extension lock **A6** by turning the locking screw anticlockwise. Slide the inner pole **A5** out all the way and secure it firmly by tightening the locking screw clockwise.
- Use a cross-head screwdriver to loosen screw **A4**. On to the inner pole **A5**, slide the control panel **A3** and secure it firmly by tightening the screw **A4**.

- Place the base with the attached control panel **A3** on a clean, even, stable and smooth surface. Place the rear protective grill **A12** against the front side of the motor unit **A2** so that the shaft **A11** passes through the centre of the grill **A12**, so that the tabs on the front side of the motor unit **A2** fit into the holes in the central part of the rear grill **A12** and so that the handle is above the motor unit **A2**. Screw the nut **A13** clockwise to secure the rear protective grill **A12** to the motor unit **A2**. Before tightening the nut **A13**, make sure that the rear grill **A12** has not moved and that the alignment tabs are still in the holes.
- On to the shaft of the motor unit **A11** put on the fan blades **A14** so that the shaft **A11** properly slides into the centre part of the fan blades **A14**. Push the fan blades **A14** towards the motor unit **A2** all the way. Now, check that the fan blades **A14** turn freely, and secure them in place by screwing nut **A15** anticlockwise on to the shaft **A11**.
- Release the clamps along the perimeter of the rear protective grill **A12**. Place the front protective grill **A16** against the rear protective grill **A12** so that the front grill **A16** fits into the alignment hook in the bottom part of the rear protective grill **A12** and so that the screw holes in the top part of the grills are aligned. Fasten the released clamps along the perimeter of the grills. To ensure a strong connection of the two grills, into the aligned holes at the top of the grills it is necessary to screw in the supplied screw and secure it with the nut.
- Before putting the fan into operation, check that it is correctly assembled and that the protective grills are firmly joined.
- To disassemble, proceed in reverse sequence.

OPERATING THE APPLIANCE

Setting the speed and turning off the fan

- Place the fan on an even, dry and smooth surface within reach of a power socket. Connect the power cord to a power socket. To set the air flow speed, use the buttons on the control panel **A3**. The functions of the control buttons are described below:
 0 – turn off the fan;
 1 – set a low air flow speed;
 2 – set a medium air flow speed;
 3 – set a high air flow speed.
- When you have finished using the fan, always turn it off and disconnect it from the power socket.

Setting horizontal oscillation

- The horizontal oscillation of the motor unit **A1** can be set using the toggle switch **A2**. To start the horizontal oscillation, push the toggle switch **A1** down. The motor unit **A2** will oscillate from side to side at an angle of approximately 90°.
- To turn off the oscillation, pull the toggle switch **A1** up. This will turn off the oscillation.

Setting the vertical tilt angle of the motor unit

- Before setting the vertical tilt angle of the motor unit **A2**, first turn off the fan. Set the desired angle of the motor unit **A2** and then you may start the fan again.



Note:

The motor unit **A2** may only be tilted up and down in a limited range. Do not set the tilt angle of the motor unit **A2** by force.

Setting the height of the fan

- The height of the fan may be set in the range from 102 to 120 cm.
- Turn off the fan before setting its height. Use one hand to firmly hold the outer pole **A7** and the other hand to release the inner extension lock **A6** by turning the locking screw anticlockwise. Slide the inner extensible pole **A5** in or out to set the desired fan height. To lock the set height in place, tighten the locking screw clockwise.

CLEANING AND MAINTENANCE

- Before cleaning it, make sure that the appliance is turned off and disconnected from the power socket.
- Regularly remove dust from the appliance. For normal cleaning, a clean, dry cloth is sufficient. In the event that it is dirtier, disassemble the appliance and then wipe the individual parts with a wiping cloth slightly dampened in a solution of warm water and neutral detergent. Then wipe everything so that it is thoroughly dry. Make sure that no water enters the motor unit **A2** or into the control panel **A3** while cleaning.
- Do not submerge the appliance or its power cord in water and do not wash it under running water.
- For cleaning do not use steel wool, cleaning products with an abrasive effect, petrol and other solvents.

STORAGE

- If you will not be using the fan for an extended period of time, store it in a clean, dry place or disassemble it and put it back into the box.

TECHNICAL SPECIFICATIONS

Rated voltage range	220–240 V
Rated frequency	50 Hz
Rated power	40 W
Electrical shock protection class	II
Noise level	54 dB(A)
Maximum fan flow rate	59.32 m ³ /min
Service value	1.78 (m ³ /min)/W
Maximum air velocity	2.80 m/s
Measurement standard for service value	IEC 60879:1986, EN 50564:2011, EN 60704-2-7:1998, EN 60704-1:2010
Contact details for obtaining more information	FAST ČR, a. s., Černokostelecká 1621, 251 01 Říčany, Czech Republic

The declared noise emission level of the appliance is 54 dB(A), which represents a level A of acoustic power with respect to a reference acoustic power of 1 pW.

Explanation of technical terminology

Safety class for electrical shock protection:

Class II – electrical shock protection is provided by double or heavy-duty insulation.

We reserve the right to change text and technical specifications.

INSTRUCTIONS AND INFORMATION REGARDING THE DISPOSAL OF USED PACKAGING MATERIALS

Dispose of used packaging material at a site designated for waste in your municipality.

DISPOSAL OF USED ELECTRICAL AND ELECTRONIC EQUIPMENT



This symbol on products or original documents means that used electric or electronic products must not be added to ordinary municipal waste. For proper disposal, renewal and recycling hand over these appliances to determined collection points. Alternatively, in some European Union states or other European countries you may return your appliances to the local retailer when

buying an equivalent new appliance.

Correct disposal of this product helps save valuable natural resources and prevents potential negative effects on the environment and human health, which could result from improper waste disposal. Ask your local authorities or collection facility for more details.

In accordance with national regulations penalties may be imposed for the incorrect disposal of this type of waste.

For business entities in European Union states

If you want to dispose of electric or electronic appliances, ask your retailer or supplier for the necessary information.

Disposal in other countries outside the European Union.

This symbol is valid in the European Union. If you wish to dispose of this product, request the necessary information about the correct disposal method from the local council or from your retailer.



This product meets all the basic requirements of EU directives related to it.